

# **Rod Extensometer**

## **51836499**

Copyright ©2004 Slope Indicator Company. All Rights Reserved.

This equipment should be installed, maintained, and operated by technically qualified personnel. Any errors or omissions in data, or the interpretation of data, are not the responsibility of Slope Indicator Company. The information herein is subject to change without notification.

This document contains information that is proprietary to Slope Indicator company and is subject to return upon request. It is transmitted for the sole purpose of aiding the transaction of business between Slope Indicator Company and the recipient. All information, data, designs, and drawings contained herein are proprietary to and the property of Slope Indicator Company, and may not be reproduced or copied in any form, by photocopy or any other means, including disclosure to outside parties, directly or indirectly, without permission in writing from Slope Indicator Company.

### ***SLOPE INDICATOR***

12123 Harbour Reach Drive  
Mukilteo, Washington, USA, 98275  
Tel: 425-493-6200 Fax: 425-493-6250  
E-mail: [solutions@slope.com](mailto:solutions@slope.com)  
Website: [www.slopeindicator.com](http://www.slopeindicator.com)

---

# Contents

Components & Planning .....	1
Installation Overview .....	2
Assembly of Steel Rods .....	4
Assembly of Mechanical Head.....	7
Assembly of Electric Head.....	10
Wiring the Electric Head.....	14
Reading VW Sensors .....	16
Reading Potentiometers .....	18
Data Reduction .....	20
Appendix 1: Packer Anchors.....	24
Appendix 2: Hydraulic Anchors....	26

# Components and Planning

**Reference Head:** Measurements are made at the reference head. Mechanical heads are read with a depth micrometer. Electric heads have sensors.

**Telescoping Joint** A telescoping joint sits between the reference head and the top of the rods. It allows adjustments in the position of the reference head.

**Rods** Fiberglass rods are supplied in continuous lengths. Steel rods are supplied in 10 foot lengths.

**Protective Tubing or Pipe** Fiberglass rods are encased in continuous lengths of plastic tubing. Steel rods are encased in plastic pipe supplied in 10 foot lengths.

**Anchors** Anchors may be groutable, hydraulic, or packer type.

**Important Measurements P, R, and A.** The drawing at right shows three measurements that are important for assembly for steel rods. Fiberglass rods are preassembled so measurements are not required.

A is Anchor depth, the distance from the top of the reference head to the top of the anchor.

R is Rod length. Rod length should be  $A - 5$  inches (127 mm). Adjust R only at the top length of rod.

P is Pipe length, which should be  $R - 17$  inches (430 mm). Cut off 10 inches (254 mm) from the bottom pipe (the pipe nearest the anchor). This staggers ends of rod and pipe for easier assembly.

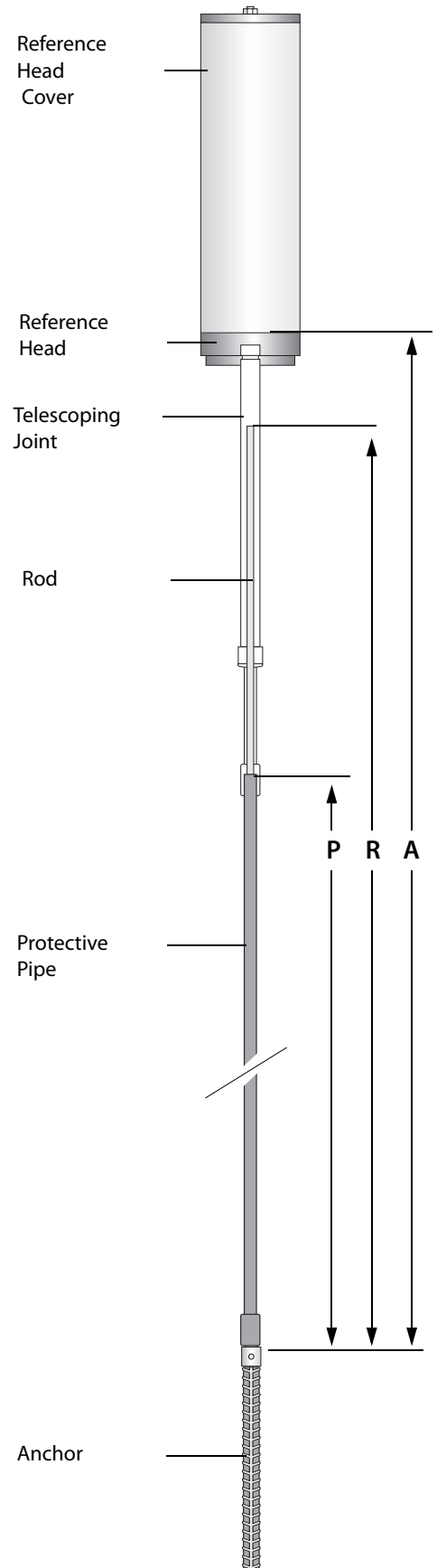

---

# Installation Overview

- Introduction** Details of the installation are usually determined by site requirements. Here, we present general information about installation, since details are often site specific. Assembly and wiring are discussed later.
- Borehole Requirements** The rod extensometer is designed for boreholes that are 60 to 96 mm in diameter (2.4 to 3.8 inches).
- Boreholes should be drilled about 1 meter (3 feet) deeper than the deepest anchor.
- Assembly** Fiberglass rod extensometers are pre-assembled, so no on-site assembly is required. Steel rod extensometers must be assembled on site.
- When space allows, pre-assemble the extensometer on the surface. Assemble the complete steel rod extensometer (except for sensors) and attach grout tubing. Park a pick-up truck near the borehole, then position your installers so that they lift the extensometer up and over the truck and down into the borehole. By lifting the extensometer over the truck, you can maintain a minimum bending radius of 3 meters or 10 feet to avoid permanently bending the rods.
- When space is tight, it is necessary to assemble the extensometer as it is installed downhole. Downhole assembly requires careful organization. Sometimes it is possible to assemble and install each anchor and rod independently, starting with the deepest anchor. A safety rope should be attached to each anchor. Grout tubing can also be attached to the anchors.
- Grouting** Use the grout mix specified by the site engineer. When grouting through long lengths of polyethylene tubing, first pump water through the tubing to minimize friction.
- Grouting Down-Holes** A single grout tube is usually adequate for vertical and inclined down-holes. Tape the end of the tube to the protective pipe near the bottom anchor. Tubing will be drawn into the borehole as the extensometer is installed. Sometimes a second, shorter grout tube is taped to a pipe about half-way down the length of the extensometer. This tube can be used if difficulties arise with the longer tube. When you begin pumping the grout, pull the grout tube free from the protective pipe. Draw it upwards as the level of grout rises in the borehole.

---

**Grouting Up-Holes**     Tape a tube to the protective pipe so that it projects beyond the deepest anchor. This will be the vent tube. Tape a second tube just below the deepest anchor. Tape a third tube to the protective pipe about 2 or 3 meters from the borehole collar.

After installing extensometer, Seal the borehole collar with rags soaked in quick-set cement. Then form a plug by pumping quick-set grout into the borehole through the shortest tube. Allow time for the plug to set.

Finally pump grout into the borehole using the longer grout tube. When grout returns via the vent tube, you know the borehole is completely grouted. Fold and tie-off tubes with wire.

**Tools and Materials**     For Steel Rod Extensometers

- Measuring tape.
- Hacksaw for cutting rod and pipe.
- Visegrips for tightening threaded rods and anchors
- Allen wrenches (supplied) for various set screws.
- PVC solvent cement for pipe joints.

For Steel Rod and Fiberglass Rod Extensometers

- Screwdrivers for wiring.
- Nylon rope or equivalent, 300 to 400 lb test strength.
- Grout tubing, grout mixer/pump, cement for grout
- Pull-in anchor and fast-set cement or grout and rags for packing borehole if installing extensometer in up-holes.
- Materials to construct concrete pad at borehole collar.

# Assembly of Steel Rods

Skip this chapter if you have fiberglass rods

## Connect Rod and Protective Pipe to Anchor

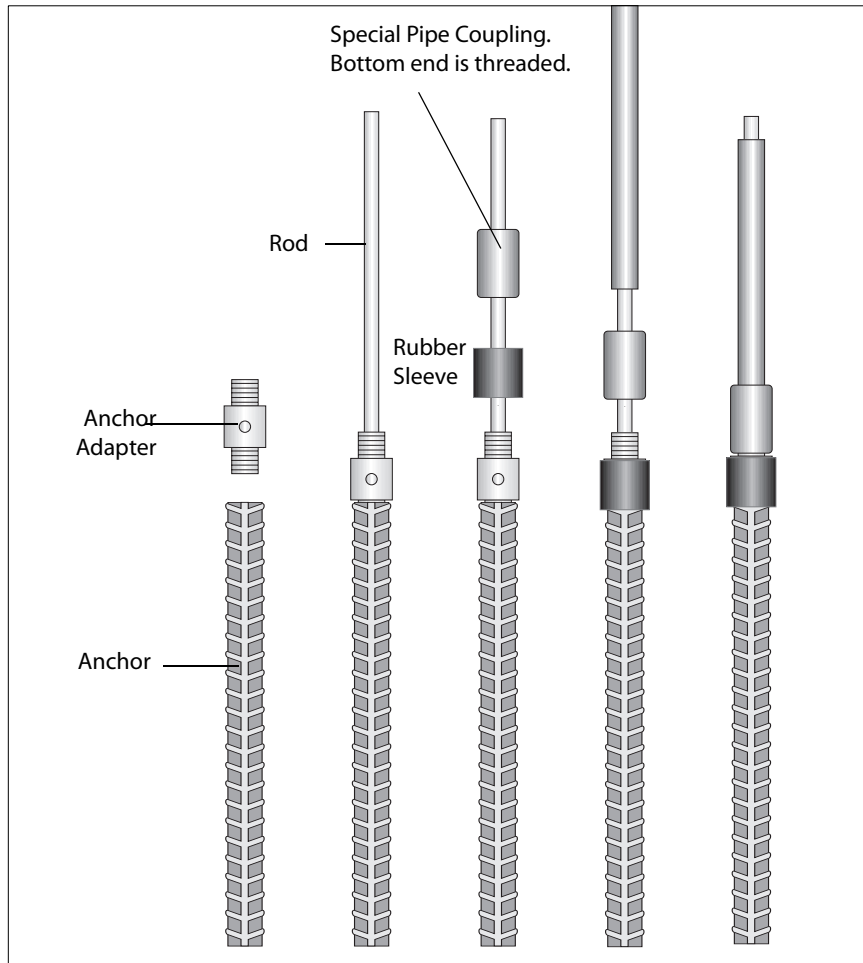

Required parts: anchor, rod, protective pipe, anchor adapter, rubber sleeve, special pipe coupling. The drawing above shows the groutable anchor. Assembly is nearly the same for hydraulic anchors and packer anchors. See Appendix 1 and 2 for more information.

1. Cut 10 inches (254 mm) off the protective pipe.
2. Screw anchor adapter into anchor.
3. Fit rod into anchor adapter. Tighten set screws.
4. Slide rubber sleeve over anchor adapter.
5. Screw special pipe coupling onto anchor adapter.
6. Glue protective pipe into special pipe coupling.

## Adding Rod and Pipe

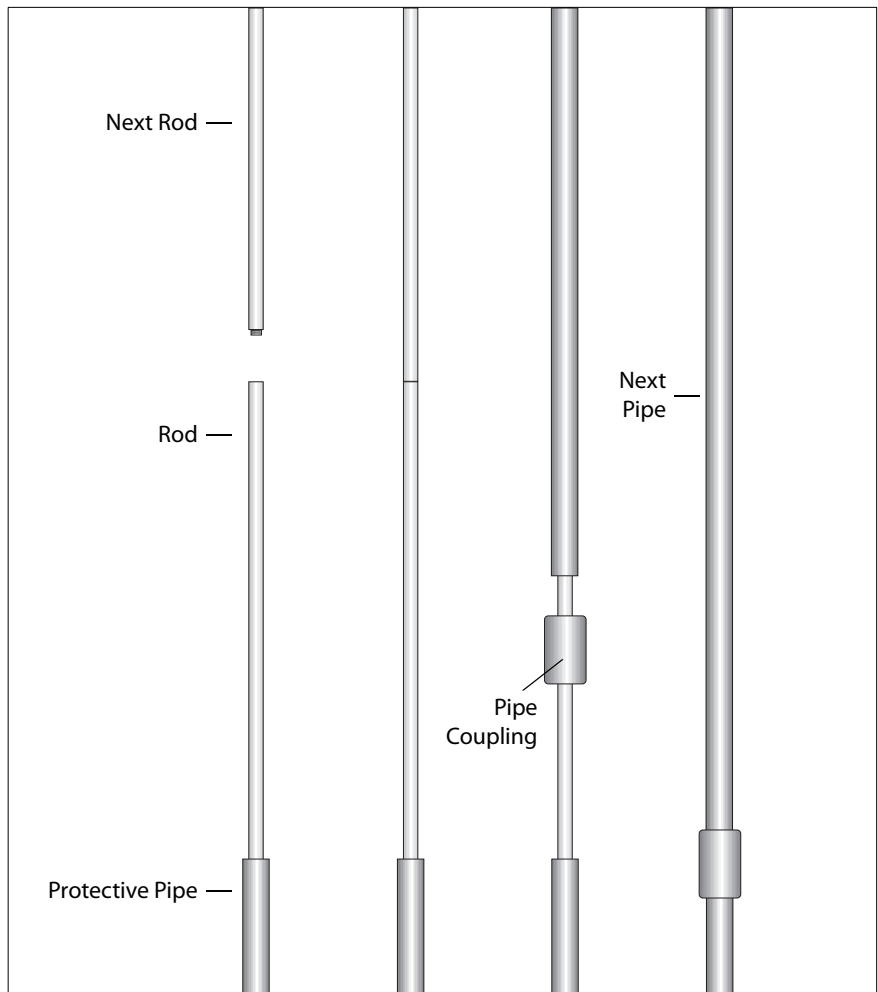

1. Required parts: rods, pipe, pipe couplings.
2. Glue coupling onto protective pipe.
3. Screw on length of rod and tighten.
4. Slide protective pipe onto rod and glue into coupling
5. Continue until correct rod length is obtained.
6. Cut the last length of protective pipe so that it ends 17 inches (430 mm) below the top of the rod. Then slide the pipe onto the rod and glue into coupling.

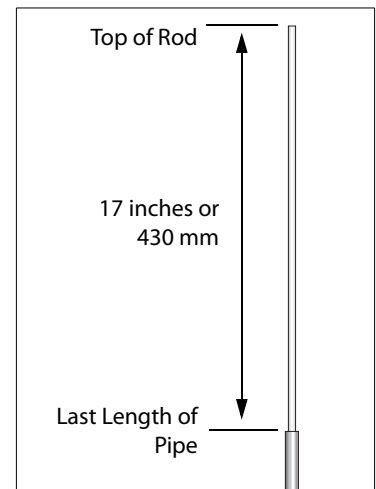

## Prepare Top of Rod

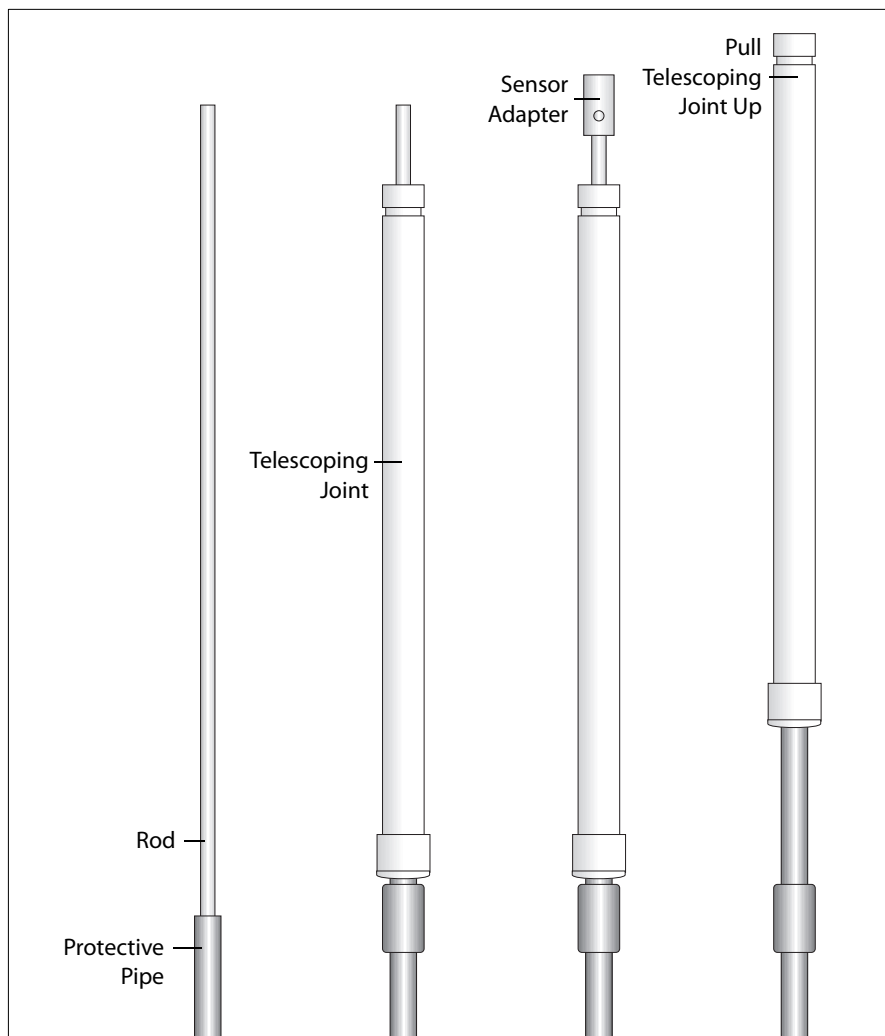

1. Required parts: telescoping joint, sensor adaptor. The sensor adaptor is used with both the electric and mechanical heads.
2. Slide telescoping joint onto rod. Glue coupling onto protective pipe.
3. Press sensor adaptor onto rod. Tighten both set screws.
4. Pull telescoping joint up over sensor adaptor.

# Assembly of Mechanical Reference Head

## Components

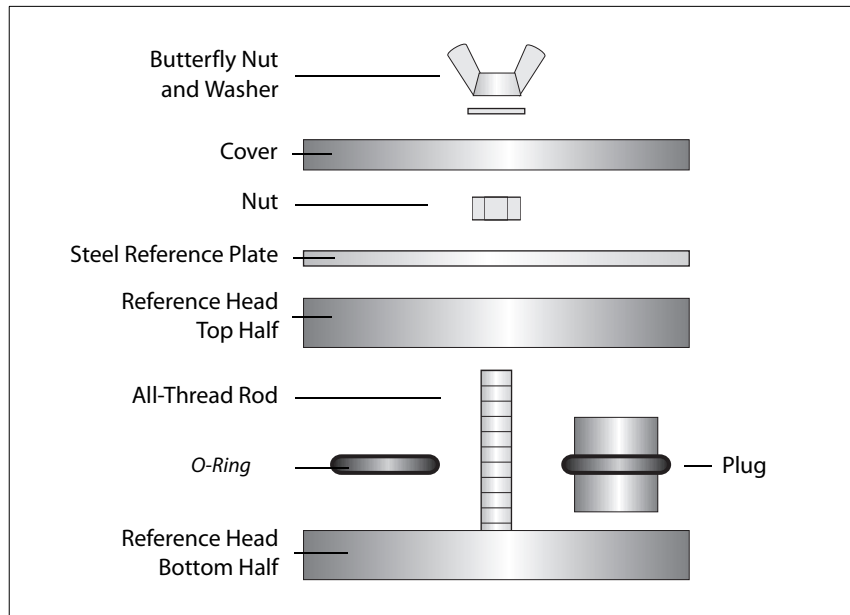

- The reference head is split into a top half and a bottom half. The center hole in the bottom half is threaded to accept all-thread rod. The center hole of the top half has no threads.
- O-rings fit onto the telescoping joints and are clamped between the top and bottom halves of the reference head. The plug fits into unused positions in the reference head.
- The all-thread rod holds the two halves of the head together
- The steel reference plate fits onto the reference head and is held by a nut.
- A flat plastic cover protects the reference plate and is held by a butterfly nut and washer.

## Connect Telescoping Joints to Reference Head

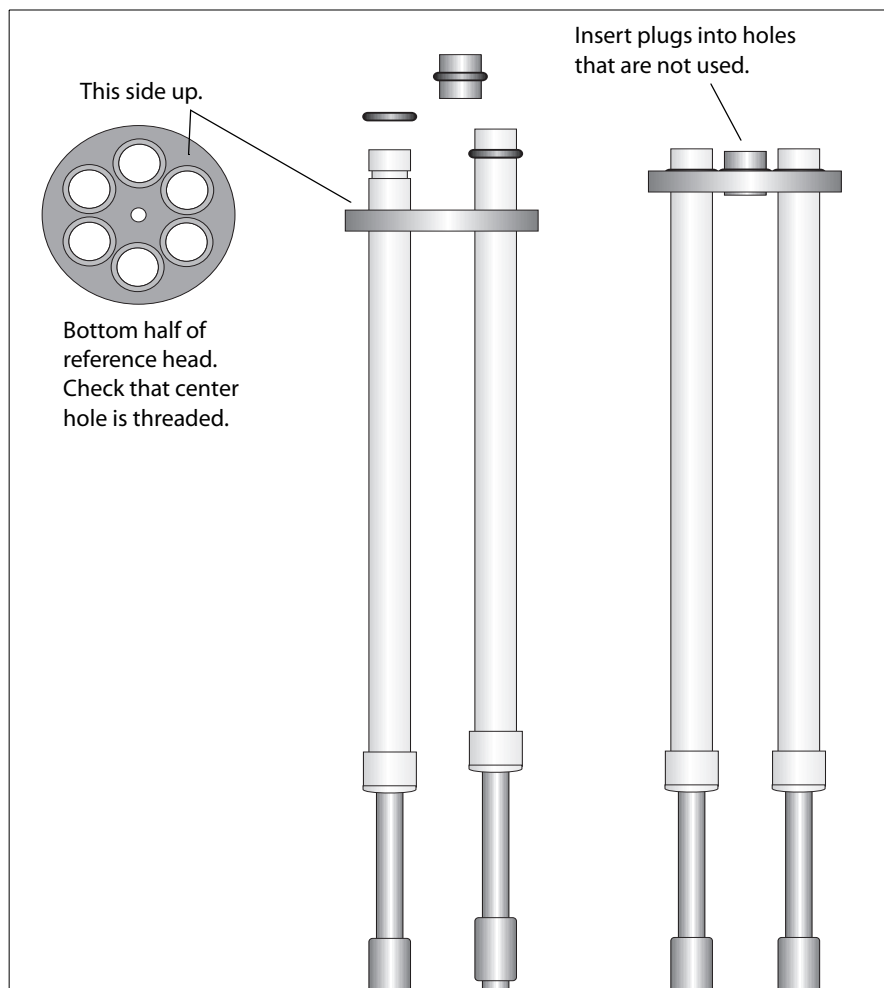

1. Required parts: bottom half of reference head (with threads in center hole, O-rings, plugs).
2. Fit bottom half of reference head over telescoping joints.
3. Fit O-rings onto telescoping joints.
4. Seat O-rings in reference head.
5. Fit plugs into holes that are not used.

## Join Top and Bottom of Reference Head

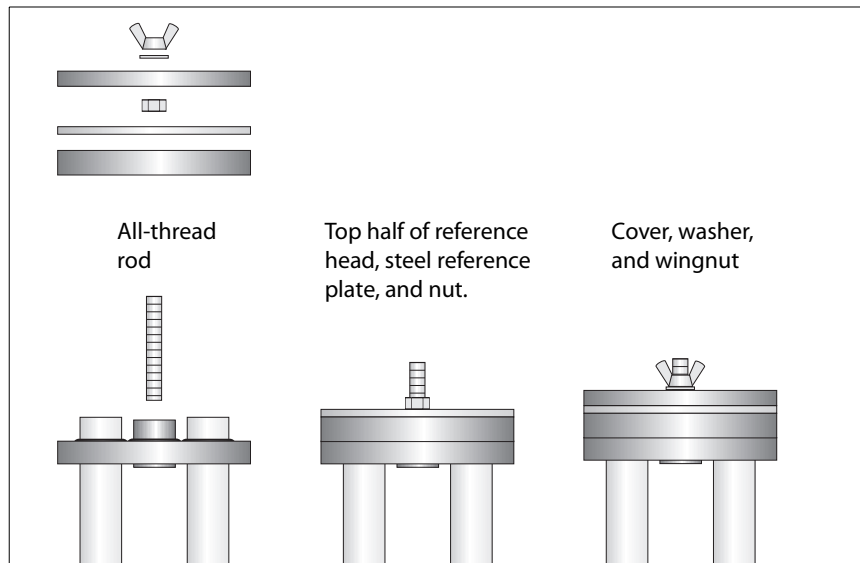

1. Required parts: all thread rod, top half of reference head, steel reference plate, nut, cover, washer, and wingnut.
2. Screw all-thread rod into bottom half of reference head.
3. Fit top half of reference head onto bottom half.
4. Place steel reference plate onto reference head. Fasten with nut.
5. Place cover onto reference plate. Fasten with washer and wingnut. Remove cover to take readings.

## Digital Depth Micrometer

If the installation goes as planned, the distance between the top of the reference surface and the top of each rod will be about 5 inches.

The depth micrometer has a 1 inch (25mm) measurement range. Its range is extended by adding or subtracting extension shafts, which are included.

6. A special foot is supplied with the micrometer to provide a flat contact surface. Be sure to use this foot.

# Assembly of Electric Reference Head

## Components of Electric Reference Head

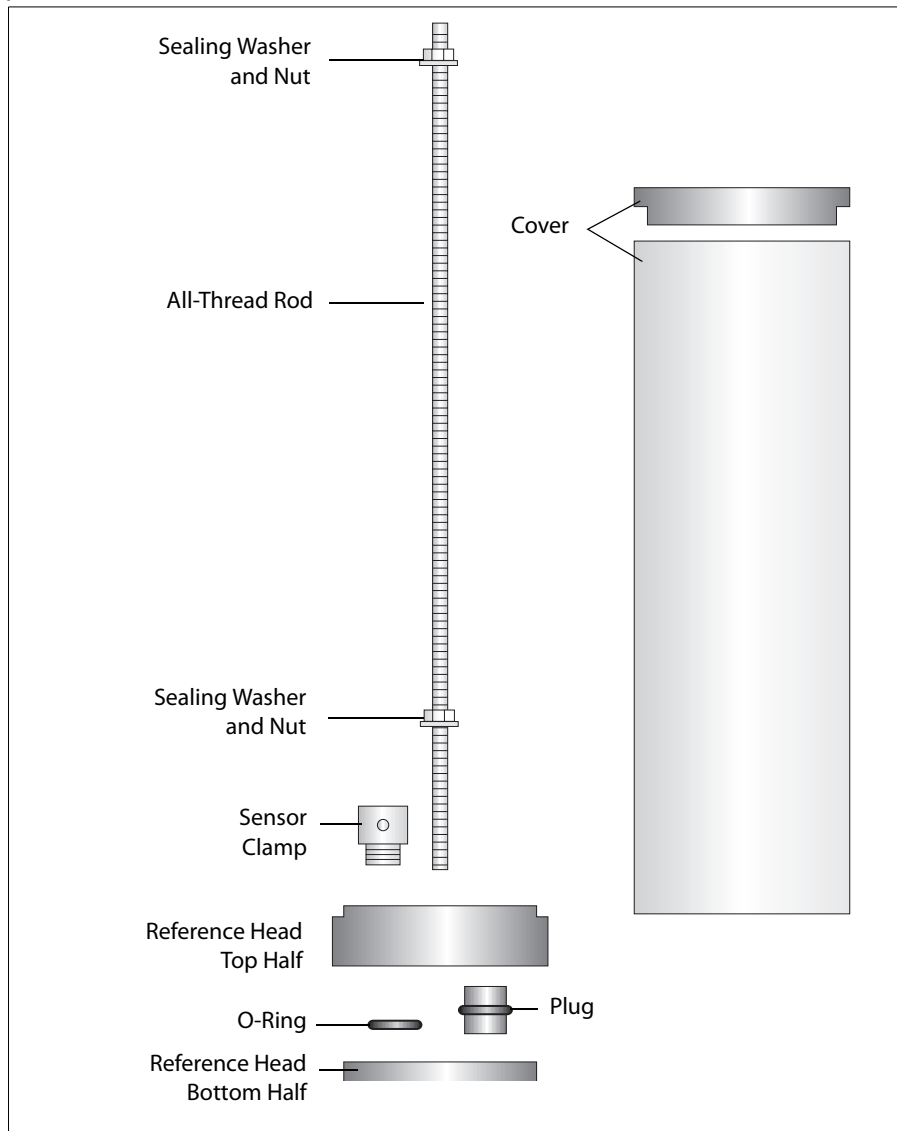

- The reference head is split into a top half and a bottom half.
- O-rings fit onto the telescoping joints and are clamped between the top and bottom halves of the reference head. The plug fits into unused positions in the reference head.
- The all-thread rod holds the two halves of the head together and also holds the cover onto the head.
- The sensor clamp holds sensors onto the reference head.
- A two-piece cover is supplied with the head.

## Connect Telescoping Joints to Reference Head

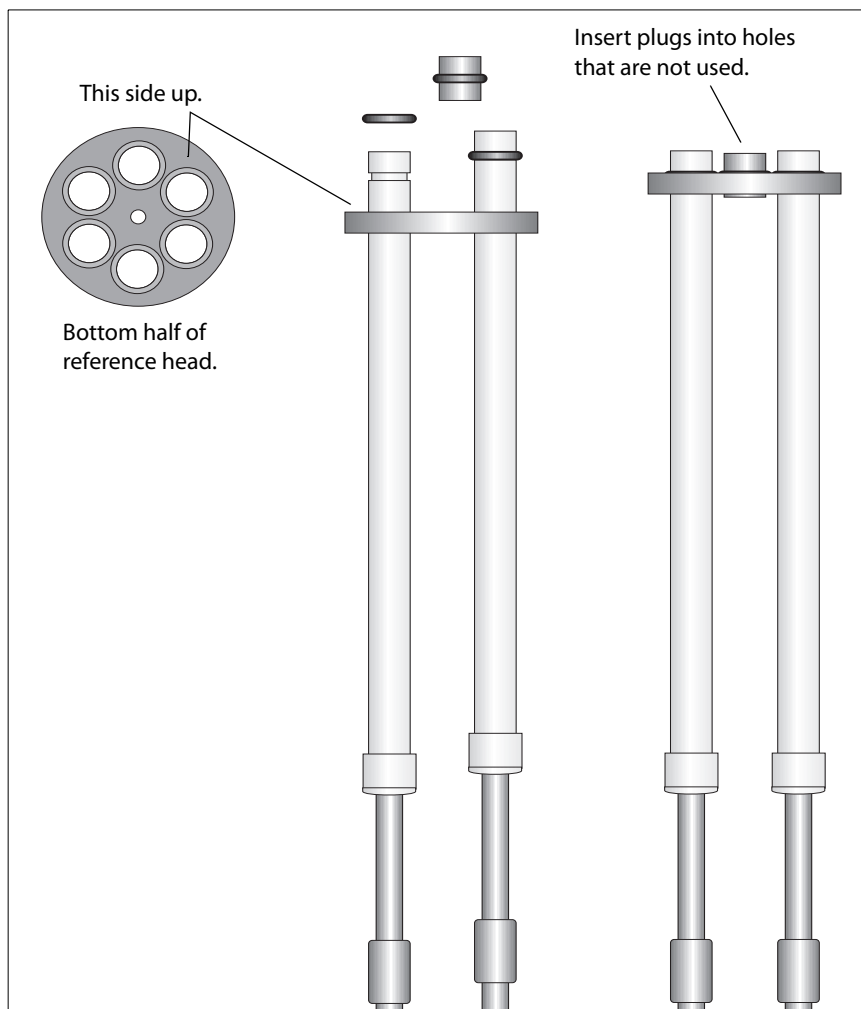

1. Parts: bottom half of reference head, O-rings, plugs.
2. Fit bottom half of reference head over telescoping joints.
3. Fit O-rings onto telescoping joints.
4. Seat O-rings in reference head.
5. Fit plugs into holes that are not used.

---

## Join Top and Bottom of Reference Head

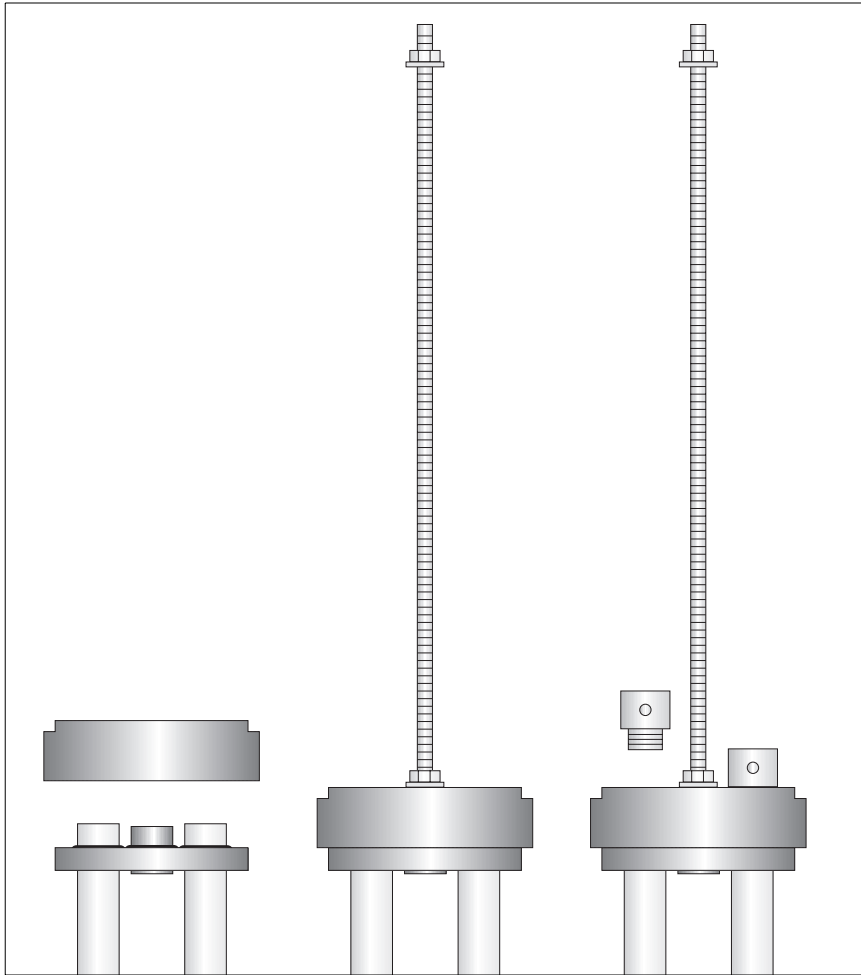

1. Required parts: top half of reference head, all-thread rod, sealing washer and nut, sensor clamps.
2. Fit top half of reference head onto bottom half.
3. Thread nut and washer onto all-thread rod.
4. Screw all-thread rod into reference head.
5. Tighten nut.
6. Screw sensor clamps into reference head. Check that set screws are accessible with allen wrench.

## Installing VW Sensors

1. Required Parts: VW displacement sensors. Note that installing sensors is the very last step in the installation process. All grouting and work around the borehole collar should be finished.
2. Screw sensor shaft into adapter at top of rod.
3. Connect readout to displacement sensor.
4. Move sensor up or down to achieve desired initial reading.
5. Tighten set screws on sensor clamps.

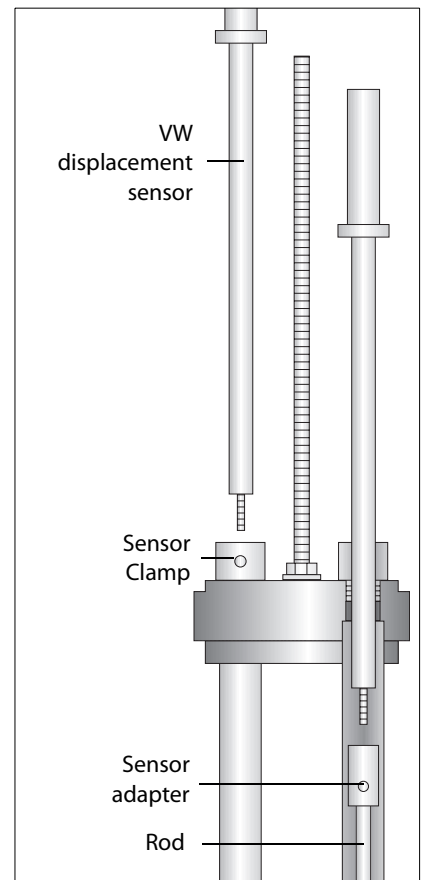

## Installing Potentiometers

1. Potentiometer shaft is fully extended by a spring. Position of shaft determines range for measuring compression or extension.
2. Slide potentiometer into sensor clamp until spring loaded shaft touches sensor adaptor at top of rod. In this position, potentiometer can measure only compression of shaft (movement of rod into potentiometer body).
3. To allow measurement of extension of shaft, press potentiometer farther into sensor clamp. If sensor adaptor at top of rod is too far away, you must replace standard tip with a longer tip.

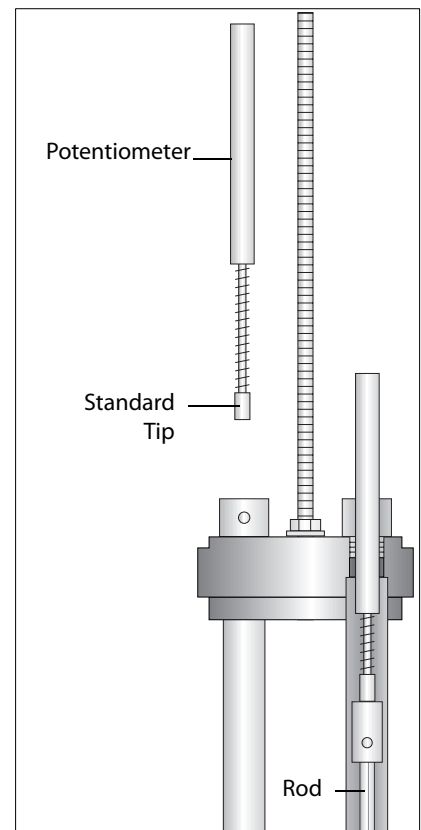

---

# Wiring the Electric Head

## Wiring VW Sensors

The table below shows the function and color coding of leads from VW sensors.

Function	Color Coding of Leads from Sensor	
VW +	Red	Orange
VW -	Black	White /Orange
Temp +	Green	Blue
Temp -	White	White/Blue
Shield	Shield	Shield

## Wiring VW Sensors to a 12-Conductor Cable

A 12 position terminal strip is supplied with the electric head, which allows connection of up to six sensors to a 12 conductor cable.

Connect VW+ wires to unique terminals. Connect VW- wires to common terminals. Connecting a single RTD temperature sensor is sufficient. The table below shows an example of connecting six VW sensors to the terminal strip. The 12-wire cable is Slope Indicator's part number 50612512.

VW Sensor	Terminal Strip	12 -Wire Cable
VW1 +	1	Brown
VW2 +	2	Red
VW3 +	3	Orange
VW4 +	4	Green
VW5 +	5	Blue
VW6 +	6	Violet
VW1 - VW2 - VW3 -	7	Yellow
VW4 - VW5 - VW6 -	8	Gray
Temp 1 +	9	White
Temp 1 -	10	Black

## Wiring Potentiometers

The table below shows the function and color coding of leads from potentiometers.

Function	Lead Color
Excitation +	Black
Excitation -	Red
Signal	White

## Wiring Potentiometers to a 12 Conductor Cable

The scheme below shows how to connect leads from the potentiometers to a terminal strip and a 12 conductor cable (part number 50612512 ) inside the extensometer head.

Potentiometer	Terminal Strip	12 -Wire Cable
Signal 1	1	Brown
Signal 2	2	Red
Signal 3	3	Orange
Signal 4	4	Blue
Signal 5	5	Violet
Signal 6	6	Gray
Excitation +	Jumper 7 and 8 together. Connect all black wires to these two terminals in any order	Green
		Black
Excitation -	Jumper 9 and 10 together. Connect all red wires to these two terminals in any order.	Yellow
		White
	Not used	Shield

---

# Reading VW Sensors

**Introduction** These instructions tell how to read VW sensors with Slope Indicator's portable readouts.

Instructions for reading VW sensors with a Campbell Scientific CR10 can be found at [www.slopeindicator.com](http://www.slopeindicator.com). Go to Support - Tech Notes and click on the link titled "CR10-VW Sensors."

**VW Data Recorder** 1. Connect signal cable to the data recorder. If you must connect to 12 wire cable, refer to the table provided for DataMate MP connections:

Binding Posts	Wire Colors	
VW	Orange	Red
VW	White & Orange	Black
TEMP	Blue	White
TEMP	White & Blue	Green
SHIELD	Shield	Shield

2. Choose Hz + Thermistor or Hz + RTD.
3. Select the 1400-3500 Hz range.
4. The recorder displays sensor reading in Hz and a temperature reading in degrees C.



**VWP Indicator** 1. Connect signal cable to the VWP indicator:

Clips	Wire Colors		Function
Red	Orange	Red	VW
Red	White & Orange	Black	VW
Black	Blue	White	TEMP
Black	White & Blue	Green	TEMP

2. Select the 1.4-3.50 kHz range with the Sweep key.
3. Select Hz with the Data key. The display shows a reading in Hz.
4. Read the RTD: Select °C with the Data key. Note that the VWP Indicator cannot read thermistors.

## DataMate MP

These instructions tell how to read using the DataMate's manual mode. Please refer to the DataMate MP manual for details of program mode.

1. Connect signal cable as shown in the table below.
2. Switch on. Press  (Manual Mode).
3. Scroll through the list to find "Vibrating Wire Hz."
4. Press  to excite the sensor and display a reading in Hz and a temperature reading in degrees C.

## Connecting to 4-Wire Signal Cables

This table shows how to connect 4-wire signal cables:

Function	Color Coding of VW Sensor Leads		Bare Wire Adapter	Universal Connector
VW +	Red	Orange	8	H
VW -	Black	White / Orange	6	F
Temp +	Green	Blue	5	E
Temp -	White	White/Blue	7	G
Shield	Shield	Shield	10	K

## Connecting to 12-Wire Signal Cables

This table shows Bare Wire Adaptor Connections for 12 wire signal cables. Sensors are read one at a time by swapping the VW+ lead connected to terminal 8:

VW Sensor	12 -Wire Cable	BWA
VW1 +	Brown	Read each VW sensor separately.  Connect VW+ lead to terminal 8
VW2 +	Red	
VW3 +	Orange	
VW4 +	Green	
VW5 +	Blue	
VW6 +	Violet	
VW1 - VW2 - VW3 -	Yellow	6
VW4 - VW5 - VW6 -	Gray	
Temp 1 +	White	5
Temp 1 -	Black	7

---

# Reading Potentiometers

**DataMate MP** These instructions tell how to read using the DataMate's manual mode. Please refer to the DataMate MP manual for details of program mode.

1. Connect signal cable as shown in the table below.
2. Switch on. Press  (Manual Mode).
3. Scroll through the list to find "Extensometer RO."

Press  to excite the sensor and display a reading in %FS.

## Connecting to Potentiometer Leads

The table below shows how to connect leads from potentiometers to the bare wire adaptor. This is probably useful only for testing the sensors. You must jumper (make a connection between) two sets of BWA terminals.

Function	Lead Color	BWA
Excitation +	Black	6 + 5
Excitation -	Red	7 + 8
Signal	White	1

## Connecting to 12-wire Cable

The table below shows how to read potentiometers one at a time by swapping the signal lead at terminal 1 of the bare wire adaptor. The 12 conductor cable is part number 50612512

Potentiometer	12 -Wire Cable	BWA
Signal 1	Brown	Read each potentiometer by connecting its signal lead to terminal 1.
Signal 2	Red	
Signal 3	Orange	
Signal 4	Blue	
Signal 5	Violet	
Signal 6	Gray	
Excitation +	Green	5
	Black	6
Excitation -	Yellow	7
	White	8
	Shield	10

---

## CR10X Data Logger

The table below shows an example of wiring a 12 conductor cable with six potentiometers to a CR10X data logger. The 12 conductor cable is Slope Indicator's part number 50612512.

Potentiometers	Terminal Strip	12 -Wire Cable	CR10X
Signal 1	1	Brown	SE 1
Signal 2	2	Red	SE 2
Signal 3	3	Orange	SE 3
Excitation - for 1, 2, 3	4	Yellow	EX 1
Excitation + for 1, 2, 3	5	Green	AG
Signal 4	6	blue	SE 3
Signal 5	7	Violet	SE 5
Signal 6	8	Gray	SE 6
Excitation - for 4, 5, 6	9	White	EX 2
Excitation + for 4, 5, 6	10	Black	AG

---

# Data Reduction

- Overview** The readings that we take at the extensometer head are used to calculate changes in the distance between the reference elevation and each downhole anchor.
- If the reference head is located on stable ground, we can calculate movements of the anchor relative to the head.
  - If reference head is not stable, then we typically use the deepest anchor as the reference elevation. In this case, the data must be inverted, so that we can calculate movements of each anchor relative to the bottom anchor.
1. If you are using the VW or potentiometer displacement sensors, convert the reading from each sensor to the desired engineering unit. No conversions are required if readings are obtained with a micrometer.
  2. Organize your data into a table, rows labeled by date, columns labeled by anchor number.
  3. Construct a table of changes by subtracting the initial reading from subsequent readings for each anchor. This shows movements relative to the reference head.
  4. If the reference is the deepest anchor, invert the data to show movements relative to the deepest anchor. This is done by subtracting the changes for each anchor from the changes at the deepest anchor.

---

## Convert Readings to Engineering Units

If you are using the VW or potentiometer displacement sensors, convert the reading from each sensor to the desired engineering unit.

### VW Readings

Each VW sensor has its own serial number and calibration sheet with unique calibration factors.

1. Use the A, B, and C coefficients listed on the sensor calibration sheet. These may be listed as “manual” factors.
2. Apply the coefficients as shown below. Note the engineering unit that the coefficients produce is typically inches for USA and mm for other countries. The resulting reading is the position of the sensor shaft. A larger value indicates extension of the shaft.

$$\text{Reading}_{\text{Engineering Unit}} = AF^2 + BF + C$$

where F is the sensor reading in Hz.

### Potentiometer Readings

Each potentiometer has its own serial number and calibration sheet with unique values for sensitivity and zero offset..

1. Find the sensitivity and zero offset values on the calibration sheet.
2. Apply the values as shown below. Note the engineering unit that the coefficients produce (either inches or mm).The resulting reading is the position of the sensor shaft. A larger value indicates extension of the shaft.

$$\text{Reading}_{\text{Engineering Units}} = \frac{\text{Reading} - \text{Zero Offset}}{\text{Sensitivity}}$$

where Reading is the sensor reading in % Full Scale

## Organize a Table of Readings

Organize your data into a table, rows labeled by date, columns labeled by anchor number. The table below shows data for six anchors. Sensors are typically wired so that extension of the sensor shaft produces larger readings. This example shows inches and feet.

Date	Anchor 1 8 ft	Anchor 2 10 ft	Anchor 3 15 ft	Anchor 4 30 ft	Anchor 5 50 ft	Anchor 6 100 ft
12 -1	1.427	1.543	1.403	1.572	1.587	1.750
12 - 2	1.426	1.543	1.403	1.571	1.586	1.747
12 - 3	1.422	1.541	1.400	1.572	1.579	1.736
12 -4	1.414	1.533	1.396	1.565	1.574	1.731
12 -5	1.393	1.513	1.373	1.555	1.559	1.711
12 -6	1.391	1.512	1.374	1.545	1.559	1.710
12 -8	1.389	1.514	1.373	1.539	1.558	1.705
12-9	1.384	1.511	1.371	1.532	1.547	1.718

## Construct a Table of Changes

This table shows changes from the initial reading. Calculate changes by subtracting the initial value from subsequent values. Positive numbers indicate extension, i.e. the distance between anchor and reference head is increasing. Negative numbers indicate compression, i.e. the distance is decreasing.

Date	Anchor 1 8 ft	Anchor 2 10 ft	Anchor 3 15 ft	Anchor 4 30 ft	Anchor 5 50 ft	Anchor 6 100 ft
12 -1	0.000	0.000	0.000	0.000	0.000	0.000
12 - 2	-0.001	0.000	-0.001	-0.001	-0.001	-0.003
12 - 3	-0.005	-0.002	-0.003	0.000	-0.008	-0.014
12 -4	-0.013	-0.010	-0.007	-0.007	-0.013	-0.019
12 -5	-0.034	-0.030	-0.030	-0.017	-0.027	-0.039
12 -6	-0.036	-0.031	-0.029	-0.027	-0.028	-0.040
12 -8	-0.038	-0.029	-0.030	-0.033	-0.029	-0.045
12-9	-0.043	-0.032	-0.032	-0.040	-0.040	-0.052

---

## Invert the Table of Changes

To show changes relative to the deepest anchor, which is presumed to be stable, the table must be inverted. Calculate values by subtracting the change value at each of the other anchors from the change value for the deepest anchor. Note that the head now has the values that previously for anchor 6. Because the reference has been inverted, positive numbers now indicate compression and negative numbers indicate extension.

Date	Head	Anchor 1	Anchor 2	Anchor 3	Anchor 4	Anchor 5
12 - 1	0.000	0.000	0.000	0.000	0.000	0.000
12 - 2	-0.003	-0.002	-0.003	-0.002	-0.002	-0.002
12 - 3	-0.014	-0.009	-0.012	-0.011	-0.014	-0.006
12 - 4	-0.019	-0.006	-0.009	-0.012	-0.012	-0.006
12 - 5	-0.039	-0.005	-0.009	-0.009	-0.022	-0.012
12 - 6	-0.040	-0.004	-0.009	-0.011	-0.013	-0.012
12 - 8	-0.045	-0.007	-0.016	-0.015	-0.012	-0.016
12 - 9	-0.052	-0.009	-0.020	-0.020	-0.012	-0.012

---

# Appendix 1: Packer Anchors

- General** The packer anchor system requires the following components:
- Packer anchors.
  - Grout tubing for each packer anchor.
  - Grout, water, and mixing tub.
  - Hand-operated grout pump. We recommend testing the grout pump with the intended grout mix grout before beginning the installation process. The water/cement ratio is not extremely important, but check that it can be pumped. Start with a ratio of 1:2 (water to cement) and modify as needed.

- Assembly**
1. Lay out components of extensometer: packer anchors, rods and protective tubing, and grout tubing.
  2. Adjust rod lengths according to instructions in the first part of this manual.
  3. Cut grout tubing long enough for easy connection to a grout pump later.
  4. Attach grout tubing to packer anchors. Note that tubing from deeper packer anchors must pass through the shallower packer anchors.
  5. Attach packer anchors to rods.
  6. Assemble rods and protective pipe. Note that rods from deeper anchors must pass through the shallower anchors.
- Optional: Use the grout pump to pump water through the tubing until it exits the packer anchor. Use this test to check the volume of water (or grout) required for the tubing. Add this to the volume of grout required for the packer.

- Installation**
1. Follow steps listed previously. Since packer anchors will be used, do not grout the borehole.
  2. To activate the anchors, follow instructions on the next page.

---

## Activation

1. Connect grout tubing to grout pump.
2. Pump clean water through the tubing. This important step prevents premature setup of the grout.
3. Pump the grout until it is hard to pump. After 1 to 2 minutes, try pumping some more to replace any grout that has leaked from the packer.
4. Pinch and fold the grout tubing to keep pressure in the packer. Tie the fold.
5. Disconnect tubing from the pump. Watch out for splashing.
6. Wash out the pump immediately.
7. Activate other anchors following the same steps.

---

# Appendix 2: Hydraulic Anchors

- Introduction** Hydraulic anchors are typically supplied with hydraulic tubing that is cut to the specified length and pre-filled with oil. A hand-operated hydraulic pump is used to activate the anchors.
- Assembly**
1. Lay out components of extensometer: hydraulic anchors, rods and protective pipe, grout tubing, and hydraulic tubing.
  2. Adjust rod lengths and assemble the extensometer according to instructions provided in the first part of this manual. The hydraulic tubing cannot be recovered, so tape it to the rods for easier installation.
- Installation**
1. Follow steps discussed previously in this manual.
  2. To activate the anchors, follow instructions on the next page.
- Activation**
1. Connect hydraulic tubing from one anchor to the hydraulic pump. Use the couplings and ferrules provided.
  2. Fill the graduated reservoir on the pump with oil.
  3. Start pumping. Pressure will build to between 800 and 1300 psi before the prongs in the anchor begin to extend and then will drop to 500 to 600 psi.
  4. The level of oil in the hydraulic reservoir will drop as the prongs continue to extend. The graphs on the next page show the relation between extension of the prongs and level of oil in the reservoir.
  5. When the anchor has been activated, disconnect the tubing from the pump and tie it off.

## Double-Acting Anchor

The graph below shows extension of the three anchor prongs in terms of a diameter of a circle. Note that both the anchor diameter and the reservoir level are in inches.

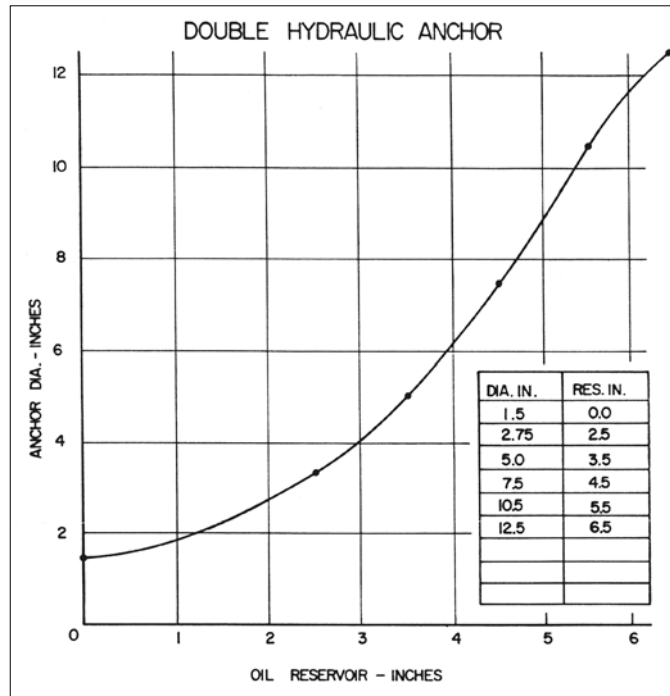

## Single-Acting Anchor

The graph below shows extension of the three anchor prongs in terms of a diameter of a circle. Note that both the anchor diameter and the reservoir level are in inches.

